

Power source regeneration of energy reuse

FANUC servo motors and amplifiers perform as “energy generators for power source regeneration”.

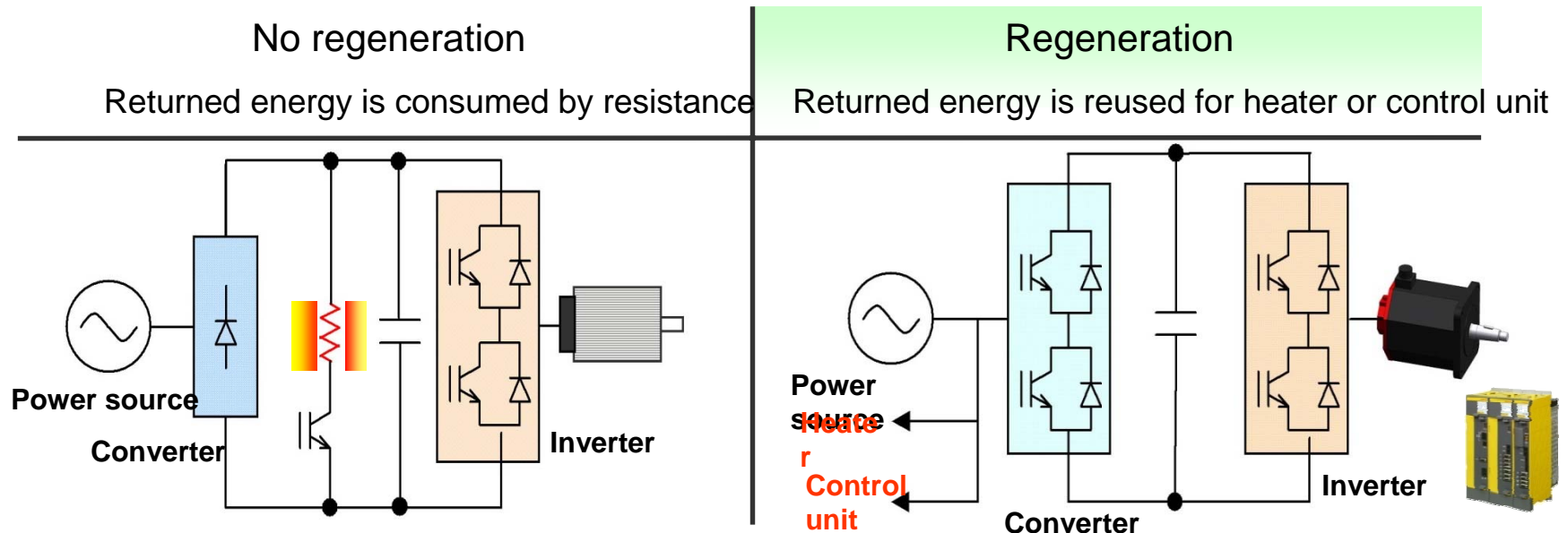
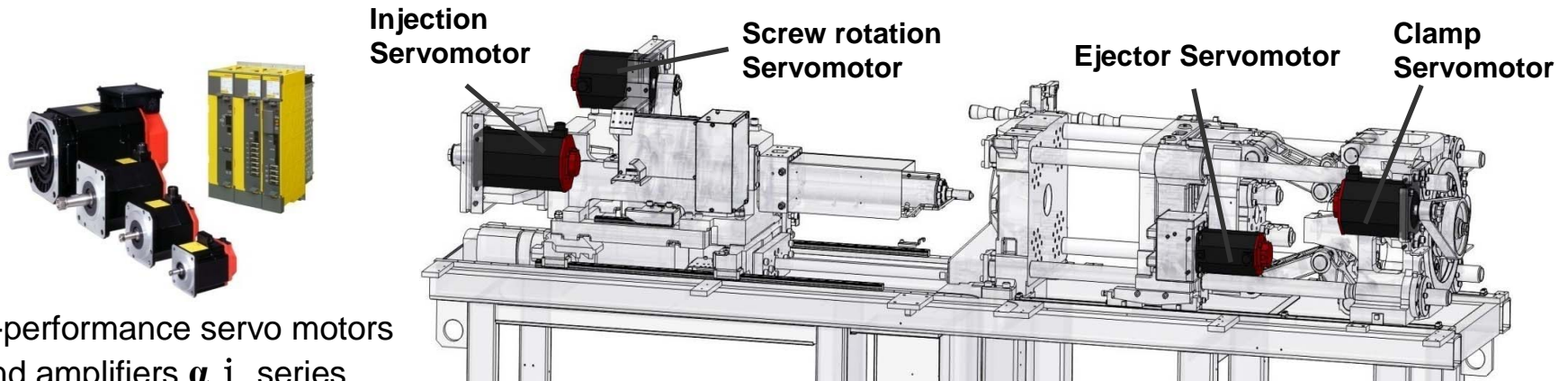

Energy saving by power source regeneration

Power source regeneration reuses the energy generated during motor deceleration and the elastic strain energy of tie bars in building tonnage.

The energy is effectively used for the heater and control unit, such that each ROBOSHOT model offers excellent energy saving.

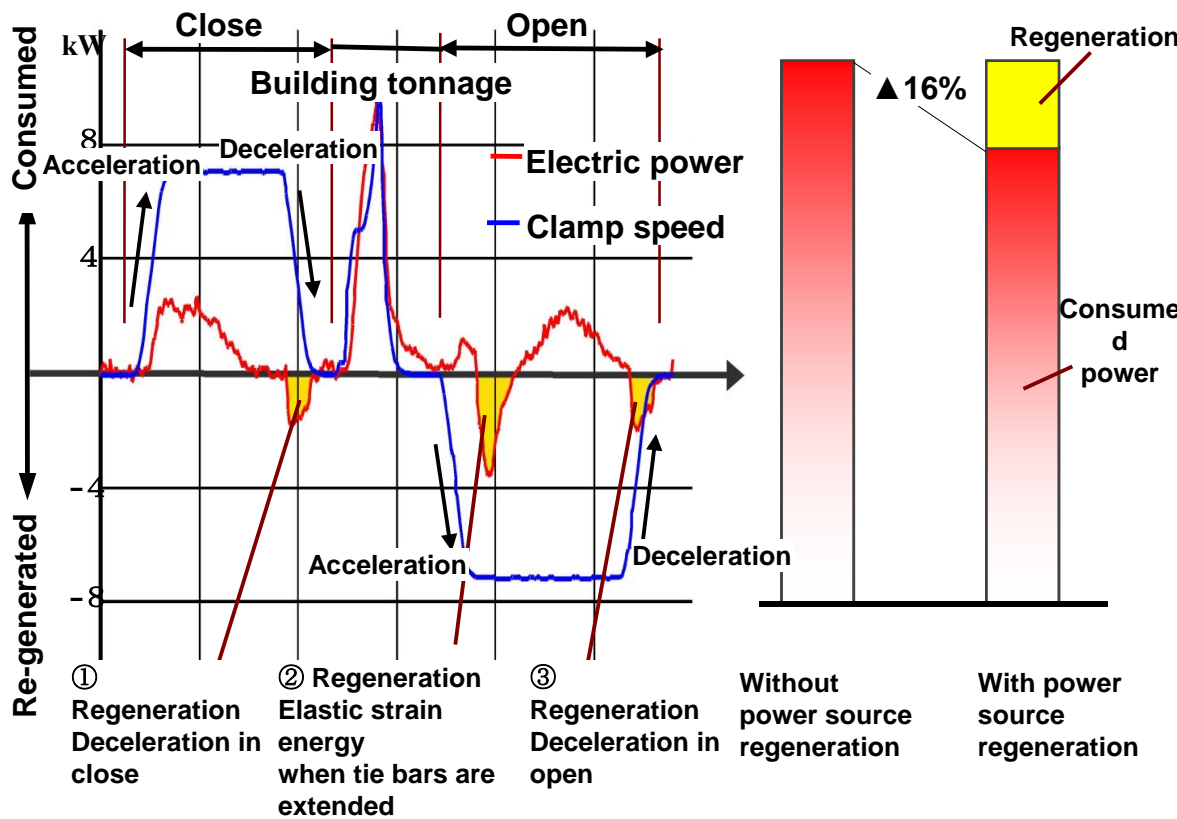

Power consumed during clamp open/close (100-t)

16% energy saving is achieved at clamp open/close on a 100-t machine with regeneration, compared to a machine with no regeneration.

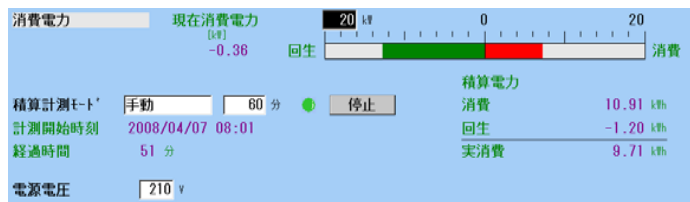

Power consumption monitor

Both consumed and regenerated power can be confirmed.

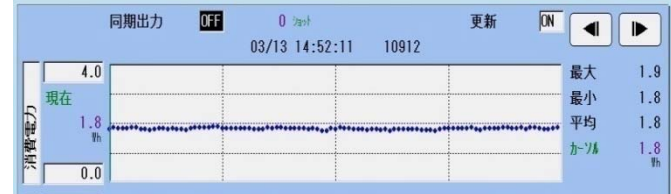

Power consumption trend chart

Power consumption per cycle is displayed by trend chart